

## Volume Rendering Of Image Using Obtained Optical Coherence Tomography

Yogendra K. Goyal, Vipin Shrivastava, Pragathi Patharia, Joseph T. Andrews\*

Applied photonics Laboratory, Department Of Applied Physics SGSITS Indore

\*Corresponding author email:jtandrews@sgsits.ac.in Fax No. 0731-2432540

[www.isroset.org](http://www.isroset.org)

**Abstract** Optical Coherence Tomography is a relatively new imaging modality giving cross-sectional images that are qualitatively similar to ultrasound. However, the axial resolution with OCT is much higher, on the order of 10 micron. Objective, quantitative measures of retinal thickness may be made from OCT images. Knowledge of retinal thickness is important in the evaluation and treatment of many ocular diseases. Qualitatively, the boundaries detected by the automated system generally agreed extremely well with the true retinal structure for the vast majority of OCT images.

**Keywords-**

**Introduction:-** Optical coherence tomography (OCT) is a non invasive and non contact technique. It gives better resolution and penetration depth in comparison to other techniques. Optical coherence tomography (OCT) is a biomedical optical imaging technology which performs high-resolution and cross-sectional tomographic imaging of internal microstructure in materials and biological system by measuring the back-reflected or backscattered light. Tomographic techniques generate slice images of three-dimensional objects. OCT derives from low-coherence interferometry. This is an absolute measurement technique which was developed for high-resolution ranging and characterization of optoelectronic components. The first application of low-coherence interferometry in the biomedical optics field was for the measurement of eye length. Adding lateral scanning to a low-coherence interferometer, allows depth resolved acquisition of three-dimensional (3D) information from the volume of biological material. The concept was initially employed in heterodyne scanning microscopy. OCT has the potential of achieving high-depth resolution, which is determined by the coherence length of the source. This is the length over which a process or a wave maintains strict phase relations; an ideal laser source, for instance, emits light with more than a few kilometres coherence length, while the coherence length of light emitted by a tungsten lamp could be as short as 1 mm. Interference takes place only between events that happen within the coherence length. Optical sources are now available with coherence lengths below 1 mm. When combined with confocal microscopy (CM), OCT adds improved depth resolution and sensitivity.

OCT is analogous to ultrasound imaging technique except that it uses light instead of sound. OCT performs imaging by measuring either the echo time delay or intensity of backscattered light from internal micro-structure in the tissue. Using OCT, image resolutions of few  $\mu\text{m}$  can be achieved which is over the one or two order of magnitude

higher than conventional ultrasound technique. Specific advantages of OCT are its high depth and transversal resolution or in fact its depth resolution is decoupled from transverse resolution.

The unique capabilities of the OCT technology, a cross sectional image from the skin on the tip of a finger. Within a depth of 700  $\mu\text{m}$ , back-scattering structures are resolved and clearly displayed such as the stratum corneum, sweat ducts and epidermis. The image provides information on subsurface structure otherwise obtainable only by histology. This explains why OCT is referred to as an optical biopsy method. Similar images, from different types of tissue, are obtainable with modern OCT tools in fractions of a second and with optical powers well below the maximum safety level. Different OCT methods and scanning procedures have been devised to generate images.

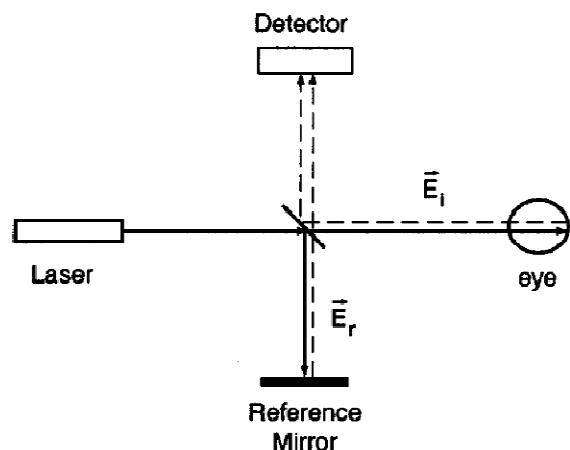

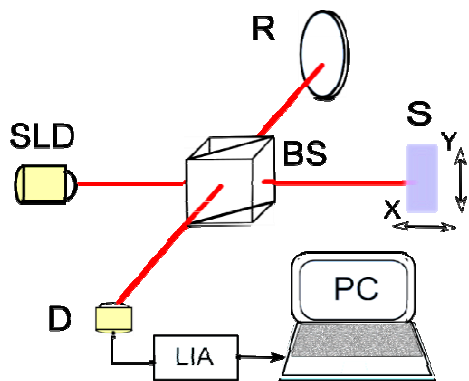

Figure 1. Schematic and ray diagrams of the OCT setup.

**Theory:-** OCT is a non invasive and non contact technique. It can provide higher resolution in order to micro meter scale. It is similar to optical low coherence reflectometer (OLCR). OLCR are based on reflecting media and so this technique can not generate the image. So this problem is overcome by OCT. OLCR has demonstrated both higher spatial resolution and reflection sensitivity when compared to direct detection techniques such as optical time domain reflectometry (OTDR) and optical frequency domain reflectometry (OFDR).

A broadband light source illuminates the interferometer, then the light is split in two: one serves as a reference beam while the other one serves as the sample illumination beam. The reflected beams from both arms are combined at the beam splitter and sent to a photodiode for detection. The interference fringes can be observed when the optical pathlengths in the sample arm and the reference arm match. In a TD-OCT system, depth information is acquired by scanning the mirror in the reference arm and the axial resolution determined by the coherence length of the light source being used.

In optical coherence tomography measurements of distance between layers of micro structures are performed using light that is back reflected and back scattered from microstructural features within the materials or tissue. OCT measurement of echo time delay are based on correlation techniques that compare the back reflected or backscattered light signal to reference light traveling a known path length. OCT is based on low coherence interferometry or white light interferometry. Low coherence interferometry has been used to characterize optical echoes and back scattering in optical fibers and waveguide devices. The velocity of light is  $3 \times 10^8$  m/s and in water or biological tissues or materials the velocity is reduced from its speed in vacuum according to the index of refraction  $n$  of the medium  $v = c/n$ . The electric field in a light wave is given by this

$$E_i(t) = E_i \cos(2\pi n t - 2\pi z/\lambda) \tag{1}$$

An OCT system is essentially a Michelson interferometer; the two light paths are called the reference path and the imaging path. Fig.1 illustrates this concept with a schematic drawing of an OCT system. In the figure, the reflected light is represented by the electric field vectors  $E_i$  in the imaging path and  $E_r$  in the reference path. Solid lines depict outgoing light and dashed lines depict reflected light. To understand OCT operation, one should first imagine the eyeball in Fig. 1 replaced by a mirror located exactly 1 m from the beam splitter. The reference mirror in this thought experiment is initially placed .5 m from the beam splitter and then slowly moved outwards to a distance of 1.5 m.

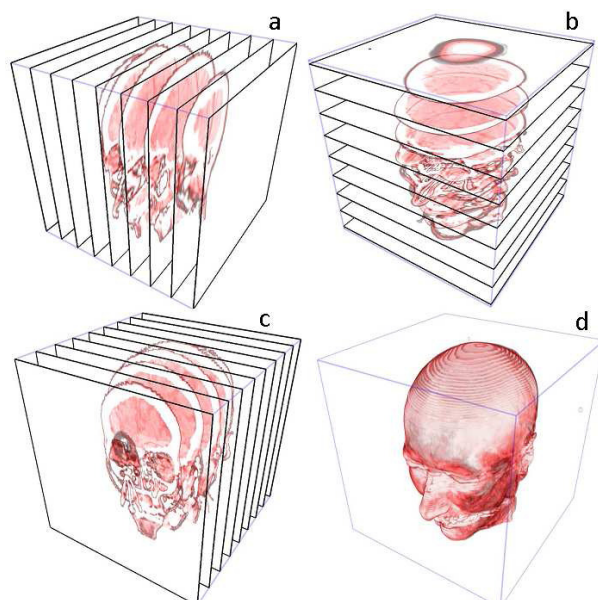

Figure 2. Process to obtain volume rendering. Various A or B or C scans as shown in Figures a or b or c are rendered to obtain a 3D image as shown in figure d.

The Optical coherence tomography (OCT) setup is based on the Michelson Interferometer. The average signal power at the detector,  $S$ , can be modeled as the real portion of the cross-correlation function between the reflected light from the imaging path and the reference path. The derivation is as follows. For a fixed reference mirror position  $d$ , the instantaneous power at the detector is, for the general case

The resultant output field amplitude at the detector is given by

$$E(t) = E_r(t) + E_s(t) \tag{2}$$

$E_s(t)$  = Field of the sample arm and  $E_r(t)$  = Field of the reference arm

$$S(t) = \parallel E_r + E_i \parallel^2 \tag{3}$$

We can simplify the notation by assuming that and both lie within the same plane (i.e., the light is linearly polarized in the same plane); thus, we can treat  $E_r$  and  $E_i$  as scalars, yielding

$$S(t) = E_r^2 + E_i^2 + 2 E_r E_i \tag{4}$$

where  $E_r$  and  $E_i$  are the magnitudes of  $E_r$  and  $E_i$ , respectively. As a final simplification, if we consider the light to be at a single frequency, we can say that

$$S(t) = (E_r + E_i) (E_r + E_i)^* \tag{5}$$

where  $E_r$  and  $E_i$  are the complex phasor representations of the two light beams and the asterisk (\*) represents complex conjugation. Equation (3) can be expanded to

$$\begin{aligned} S(t) &= |E_r|^2 + |E_i|^2 + E_r E_i^* + E_r^* E_i \\ &= |E_r|^2 + |E_i|^2 + 2\text{Re}(E_r E_i^*) \end{aligned} \tag{6}$$

and the time average taken to yield

$$\langle S(t) \rangle = \langle |E_r|^2 \rangle + \langle |E_i|^2 \rangle + 2\text{Re} \langle E_r E_i^* \rangle \tag{7}$$

If we now allow to vary, we note that  $E_r$  and, thus,  $S$  vary in response. However,  $E_i$  does not vary with  $d$  and always equals  $E_i(0)$  and so  $E_r E_i^*$  can be written as  $E_r(0) E_i^*(d)$ . Also, the average power of  $E_r$  and  $E_i$  are assumed to be constant and so

$$S(d) = C + 2\text{Re} \langle E_i(0) E_r^*(d) \rangle \tag{8}$$

where  $C$  represents a constant offset. The rightmost term in (8) is the definition of a cross correlation. In our thought experiment, a mirror terminates both light paths and so the cross correlation is the autocorrelation function of the light source.

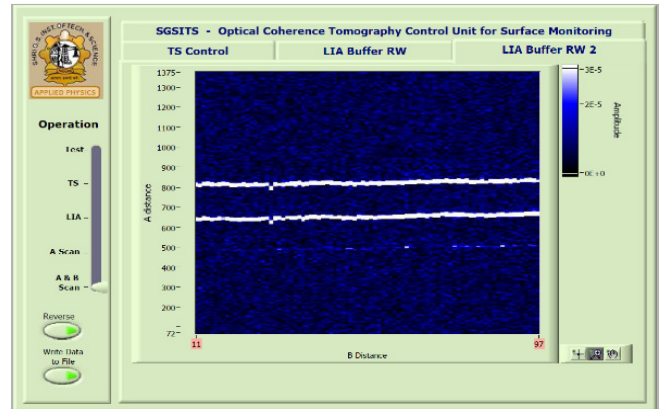
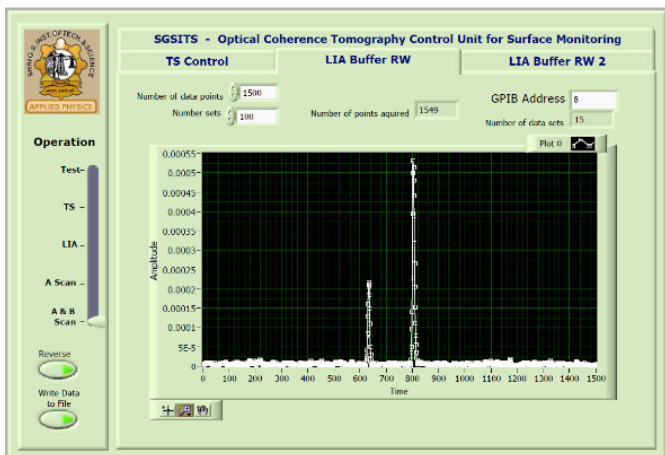

Figure 3. The Front panels of software used to obtain tomograms. The Images are aligned before making the volume rendering process.

**Volume Rendering:** -Volume rendering is a visualization method for the 3D visualization of medical images. It converts 1D to 2D image and 2D to 3D image. By using appropriate software, we stitched the 2D images to make a 3D image. The image rendered could be rotated along all possible directions. A sample image obtained is shown in Figure 4. The various panels exhibit possible image planes which could be readable using the software.

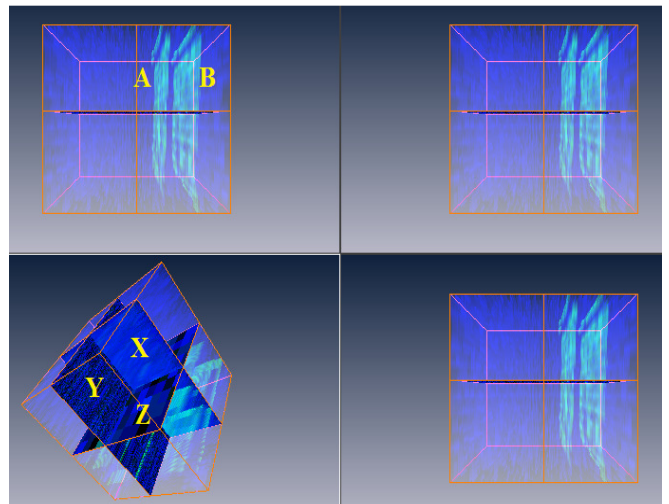

Figure 4. The volume rendered images after stitching 256 tomograms of glass slides. The A and B scan planes shown in first figure.

**Result &Conclusions:-**Using appropriate software and suitable automation methods we could obtain tomograms using optical coherence tomography setup. The images are stitched to obtain 3-dimensional images after volume rendering. The results are shown in the text.

**Reference**

[1]. Hang D. et al, Science **254** (1991) 11878-81.

- [2]. Dara Koozekanani, Kim Boyer, 'Retinal Thickness Measurements From Optical Coherence Tomography Using a Markov boundary Model' **20** (2001) 900-16.
- [3]. Yubo Zhang ; Kwan-Liu Ma, 'Lighting Design for Globally Illuminated Volume Rendering', **19** (2013), 2946-2955.
- [4]. Yu Chen, Shu-Wei Huang, Chao Zhou, Benjamin Potsaid, and James G. 'Improved Detection Sensitivity of Line-Scanning Optical Coherence Microscopy', **18** (2012) 1094-1099.
- [5]. J. Solanki, P. Sen, J. T. Andrews, K. K. Thareja, Cyclic Correlation of Difuse ReConcentration and Scatterer Size, J. Modern Physics, **3** (2012) 63-68.