



Design of Analog Circuits Using Pseudo Floating Gate

Sonalee P. Suryawanshi^{#1}, Ishan S. Chintawar^{#2}

^{#1}Department of Electronics Engineering, GHRIETW, Nagpur, 441110, India, Email: ssuryawanshi29@yahoo.com

^{#2}Department of Electronics Engineering, DBACER, Nagpur, 441110, India, Email: chintawar.ishan@gmail.com

Abstract - In this paper we present pseudo floating gate and its bidirectional property. Inverter also can be implemented using bidirectional property. The inverter can be made bidirectional simply by interchanging vdd and gnd and no need to add any circuitry or any amplifier. We are using this inverter to implement the differentiator and integrator. We are first implementing inverter using pseudo floating gate. The bidirectionality of the gate is further evolved to be able to control signal flow conditions. And finally using this inverter we are implementing differentiator and integrator. A bidirectional PFG gate is designed which is used to implement different bidirectional PFG amplifiers that includes single to differential amplifier, differential to differential amplifier, high gain differential amplifier, differential to single ended amplifier. The PFG inverter enables design of analog multifunctional, multi-directional circuits. Typical applications are in filter design and IO ports in ICs. Linearity and AC simulations are presented to show the good properties and versatility suited for Bi-directional analog circuit design.

Keywords— Semi floating gate (SFG), Pseudo floating gate (PFG), Non-volatile floating gate (NFG).

1. INTRODUCTION

Capacitively connecting the input signals to the transistor we achieve a floating-gate (FG). As the name implies, the gate is actually floating gate technology has beginning in late sixties, and now becoming mature technology. Kahng and Sze first proposed the concept of floating gate device in 1967. The first commercially available floating gate based memory, the floating gate avalanche MOS device was (FAMOS) was developed in 1970. The initial charge on the floating-gates may vary significantly and Therefore, substantial inaccuracy may occur unless some form of initialisation is applied. In order to control or assert a desired voltage level different techniques are available [1,3,6].

Floating gate can be categorised as follows:

- Non-volatile floating-gate (NFG). Programmed by use of Fowler-Nordheim Tunneling, hot carrier injection or UV activated conductances. Used as non-volatile analog memories in neural systems, and used for threshold shift for low-voltage/low-power digital (binary and multiple valued) and analog circuits. No leakage and hence no requirement for keeping the non-volatile-floating-gates at a specific dc level.
- Semi-floating-gate (SFG): Initialized, or recharged, frequently through active devices (transistors). The SFG circuits resembles analog switch-cap circuits or pre-charge logic. SFG circuits can be used to implement digital (binary and multiple-valued) and analog circuits. The frequency of the recharge is determined by the global clock signals. There is a significant leakage at the floating-gates due to the switches connected to the gates.
- Pseudo floating-gate (PFG): Initialized through passive components or transistors operating in weak inversion. A local feedback will force the pseudo-floating-gate and the output of a gate towards an equilibrium state when dc

inputs are applied. The weak initialization is continuous processes which will have no effect when “high” frequency input signals are applied. Continuous leakage forcing the floating-gate and the output of a gate towards the equilibrium state, preferably $V_{pfg} = V_{out} = V_{dd}/2$. The dc level for the output of the PFG gate will be equal to the equilibrium voltage[1,2].

In section II we present a analog PFG inverter and describe the inverters operation principle. In section III the bi-directional inverter is introduced. In section IV a PFG differentiator circuit is presented along with its transient and AC simulation. In section V a PFG integrator circuit is presented. In section VI a PFG Amplifiers is presented which includes four type of amplifiers i.e. single to differential amplifier, differential to single ended amplifier, differential to differential amplifier and differential to differential high gain amplifier. In section VII is conclusion of the work. The simulations presented are being done with 90 nm CMOS transistor models with a VDD equal 1.2 volts.

II. PFG INVERTER

The analog PFG inverter is shown in figure 1. This circuit is an current-starved inverter with a weak positive feedback. The positive feedback circuitry is basically a current starved inverter where the PMOS transistors are connected between the output and GND and the NMOS transistors between output and VDD, the opposite of the inverter [3,4,5]. This positive feedback has 2 important functions in the circuit, it sets the operational point (DC level) of the circuit and it decides the lower cut-off frequency. Bias voltages on Vhf and Vlf limit the current flowing through the inverter and the feedback circuitry respectively. Input capacitances, C1 and C2, block DC signals from the other circuitry connected to the inputs and make the circuit floating C1 and C2 can also be used for weighting the input signals compared to each other simply by choosing the right values.

Corresponding Author: Sonalee P. Suryawanshi^{#1}

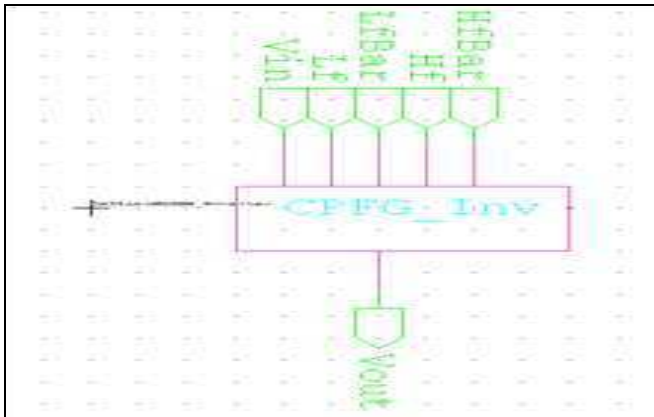

Figure1: symbol for PFG inverter

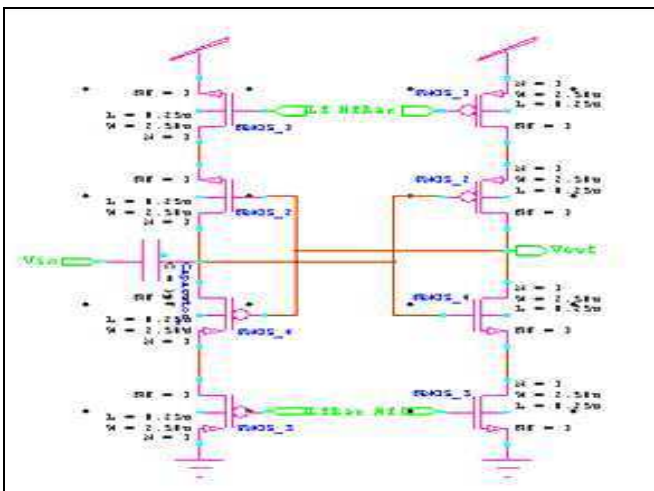

Figure2: PFG inverter

III. BIDIRECTIONAL PFG INVERTER

Bidirectional PFG inverter which is obtained simply by swapping the vdd and gnd and hence no extra circuit or amplifier is required to make it bidirectional. The response of PFG inverter and bidirectional PFG inverter is shown in fig 3.

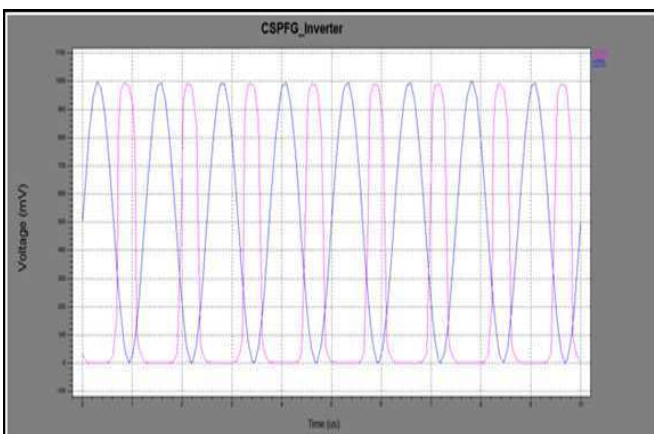

Figure3: input output waveform of inverter

IV. PFG DIFFERENTIATOR

Figure 4 shows a CSPFG Differentiator. The differentiator is implemented using three inverter i.e the one forwarding inverter and a feedback circuitry consisting two analog inverters. This circuit produces an output voltage that is

proportional to the rate change of the input voltage. This we are going to implement. Figure 5, 6 shows the various responses of differentiator.

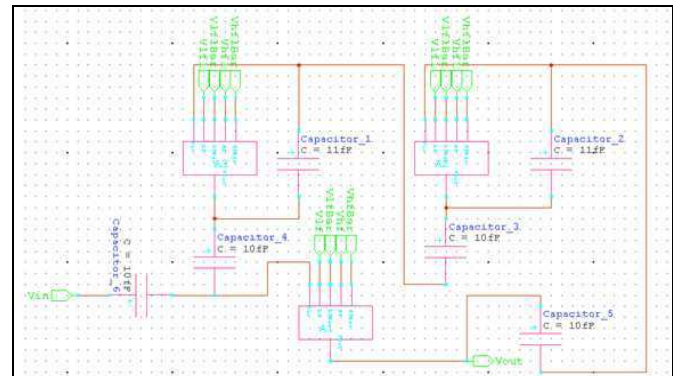

Figure4: Differentiator using PFG inverter

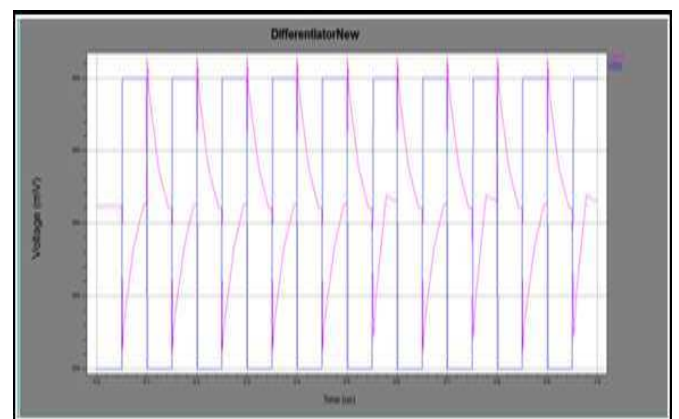

Figure5: PFG differentiator response for pulse wave

Figure 5 shows the circuit response to a square wave. We see that the output instantly jumps and settles fast to the circuits. Figure6 illustrates the differentiator response to a triangular wave. The output is a square wave with opposite sign. From the figure we see that the corners of the square wave are being rounded resulting in a rise and fall time. The limitations in high frequencies are not so dominant here because the circuit can operate with very high frequencies.

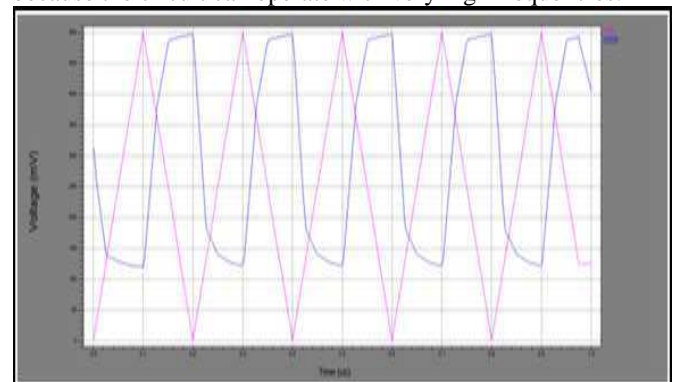

Figure6: PFG differentiator response for triangular wave

V. PFG INTEGRATOR

The PFG integrator can be design by using by using three PFG inverter one forwarding inverter and two inverter in a feedback same as differentiator only we have to swap vdd and gnd. And then we have to give input to the integrator.. A simple definition of the integrating circuit can be a circuit that produces an output voltage which is proportional to the area

contained under the input wave form. The response for square wave input is shown in figure 7. The design of integrator is same as differentiator as shown in figure 4 just we have to swap its supply voltages.

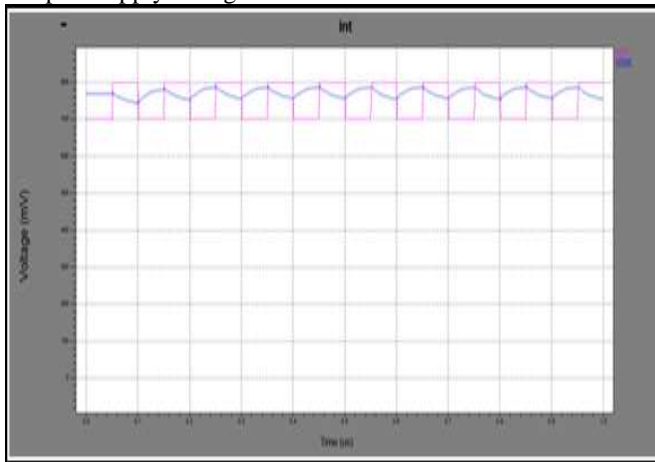

Figure 7: Response Of Integrator For Square Wave Input

VI. PFG AMPLIFIERS

A new type of amplifier based on Inverters is designed, or more accurate Pseudo-Floating Gate (PFG) inverter [4]. These amplifiers are purely analog, high speed and power conservative. One advantage compared to operational amplifiers is that the bandwidth of the active component (amplifier) can be changed without adding external components or changing the design of the circuit, well suited for filter design. The first analog circuit based on PFG was a band pass amplifier [3]. One important property of that amplifier was that the pass area could vary simply by changing a few bias voltages. Figure 8, 10, 12, 14 shows design of different amplifiers and figure 9, 11, 13, 15 shows responses of thus amplifiers. A simple differential to single-ended amplifier is shown in Figure 8 By flipping the supply voltages and the biasing voltages we reverse the signal flow from right to left as shown in Figure 10 and the circuits becomes a single ended to differential amplifier. The capacitance is typically in the order of a few Ff.

A. Differential To Single Ended Amplifier

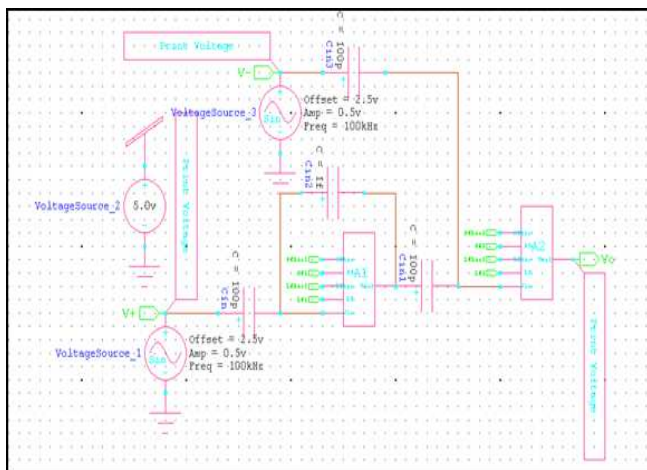

Figure 8: Design of differential to single ended amplifier Using PFG Inverter

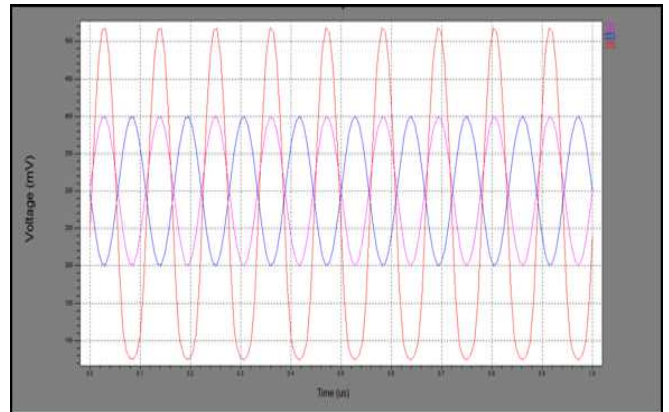

Figure 9: Response of Differential to Single Ended Amplifier Using PFG Inverter

B. Single to Differential Ended Amplifier

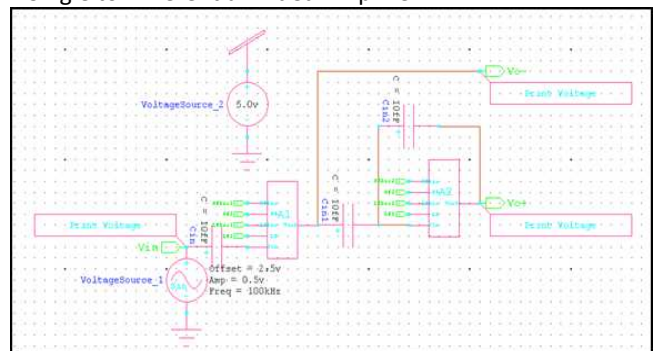

Figure 10: Design Of Single To Differential Ended Amplifier Using PFG Inverter

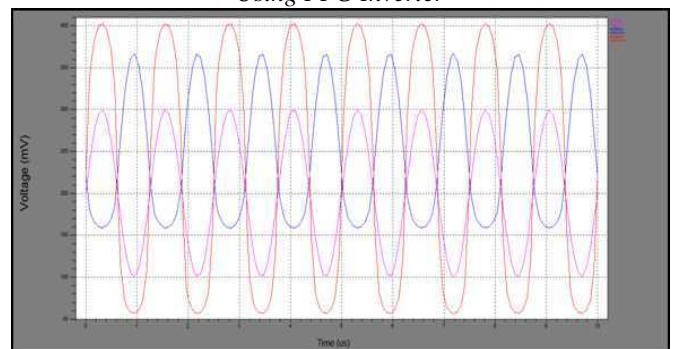

Figure 11: Response of Single To Differential Ended Amplifier Using PFG Inverter

C. Differential To Differential Amplifier

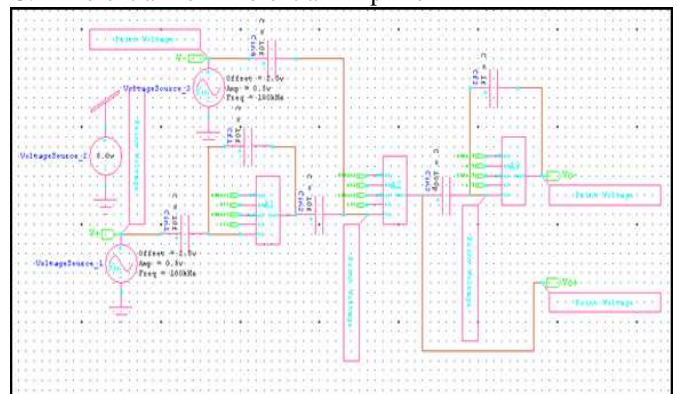

Figure 12: Design of Differential To Differential Amplifier Using PFG Inverter

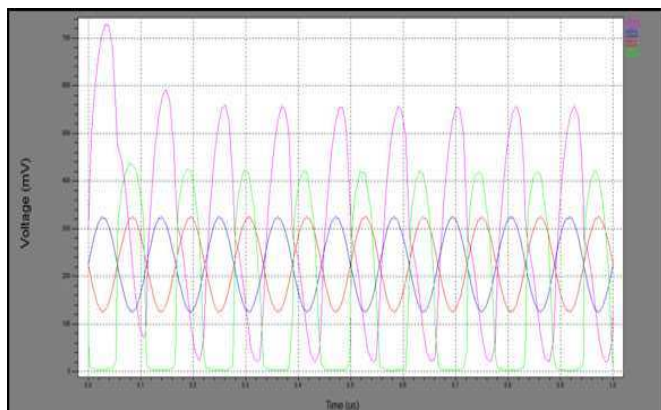

Figure 13: Response Of Differential To Differential Amplifier Using PFG Inverter

D. Differential To Differential High Gain Amplifier

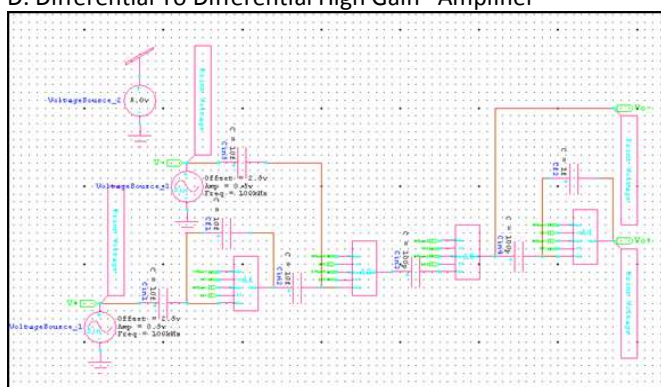

Figure 14: Design Of Differential To Differential High Gain Amplifier Using PFG Inverter

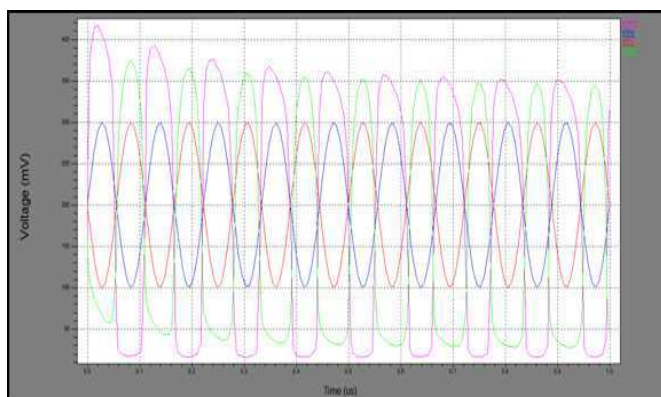

Figure 15: Response Of Differential To Differential High Gain Amplifier Using PFG Inverter

VII. CONCLUSION

These circuits have the advantages offered by PFG inverters such as high gain and ability to adjust the frequency behaviour. The PFG inverter enables design of analog multifunctional, multi-directional circuits. The bi-directional differentiator presented in this paper is useful in filter and high frequency circuit design. In theory these circuits can be used to construct analog computer which can solve differential equations in continuous time. The circuits presented here have the ability to change their functionality and operation direction simply using a few control signals. The basic pseudo floating gate current starved inverter is symmetric with respect to the supply rail,

and the signal flow can be altered by flipping the supply rails. Different circuits configurations, including a differential to single-ended amplifier, single-ended to differential amplifier, follower integrator and differentiator circuits are designed. These all design is used for low voltage application. The PFG inverters in future can replace operational amplifiers in many applications to ease the design, especially in filters and high frequency signal processing.

REFERENCES

- [1] M. Azadmehr, y. Berg. "bi-directional current starved pseudo-floating-gate differentiator / integrator", proc, ieee international conference on electronics, circuits and systems, icsc 2008 malta.
- [2] O. Mirmotahari, y. Berg "reconfigurable pseudo floating-gate analogcircuits" ieee international conference on electronics, circuits and systems,2010
- [3] O. Mirmotahari, y. Berg. "proposal for a bidirectional gate using pseudo floating gate", ieee international symposium on electronic design, test and applications, 2008.
- [4] Shweta p. Hajare and monica v. Mankar "implementation of cmos ad/da converter using pseudo floating gate" ieee international conference on advances in recent technologies in communication and computing 2010.
- [5] Shweta p. Hajare and monica v. Mankar "multiple-input multiple-valued pseudo -floating gate dac" ieee international conference on advances in recent technologies in communication and computing 2010.
- [6] Y. Berg, m. Azadmehr, o. Mirmotahari, s. Aunet. "band pass pseudo floating-gate amplifier", ieee international conference on electronics, circuits and systems, icsc 2007.